

# CONTENTS

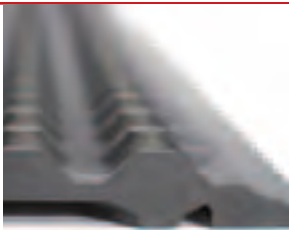

**Ergonomic Mats**



100

**Shadow Board**



101

**UT-Box Screw  
Material Picking**

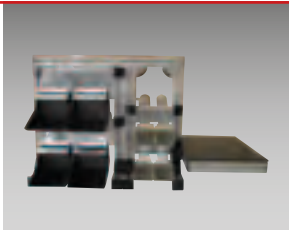

102

**Manipulators  
for Screwdrivers**



104

## Ergonomic Mats

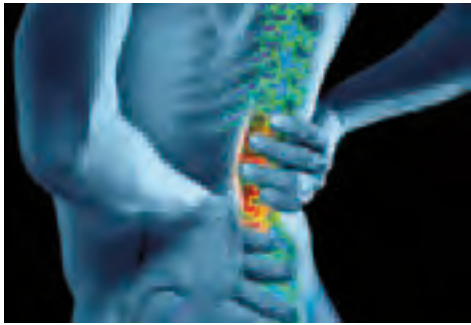

### DESCRIPTION AND VERSIONS

Ergonomic mats of low-density polyurethane and with ergonomic design



ER-001



ER-002



ER-003



ER-004



ER-005



ER-006



ER-007



ER-008

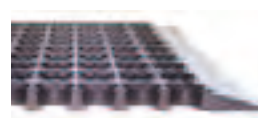

ER-009



ER-0010

Our ergonomic mats are designed to improve ergonomics and quality in all environments. They reduce back, legs and feet pains and muscle tensions.

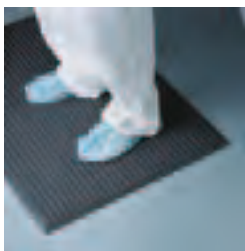

Classic ER



Nitrile ER



Soft ER

Broad range of ergonomic mats for every application. Resistant to: wear, oils, solvents.

Thanks to modularity all shapes can be realised at the same price.  
Debarred edge.

**Our ergonomic mats are not only anti-fatigue, but also salutary.**

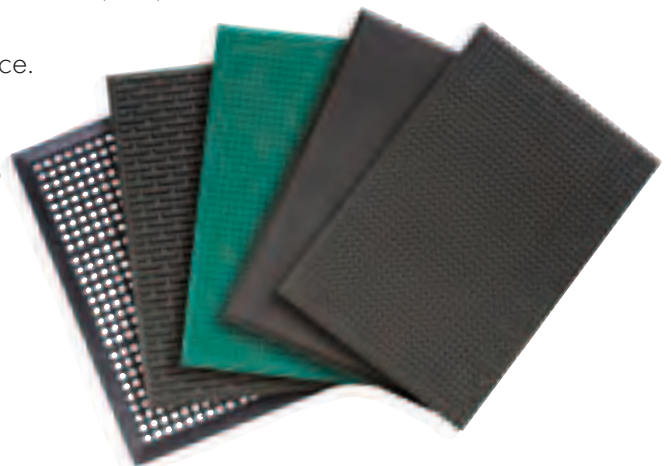

## Shadow Board and Hooks



Perforated panels can be fixed to workbenches. All tools can always be tidy and through a broad range of available hooks within reach.

Material: Steel sheet. Thickness: 1.25mm. Holes: 10x10mm with bevelled edges. Ideal for workstations or as wall solution.

### DESCRIPTION

#### Steel perforated Panels

Dimensions (L x H) mm	495x457	991x457	1486x457	1981x457
Code	140 25 115.**	140 25 117.**	140 25 118.**	140 25 119.**



#### Hooks and Accessories for perforated Panels

Order means having all tools in their place!  
Hooks are designed for every kind of tool.  
Strong hooks for industrial application.



**SG-001**  
Basket



**SG-002**  
Hook



**SG-003**  
Combination holder



**SG-004**  
Basket



**SG-005**  
Media box



**SG-006**  
Shelf



**SG-007**  
Ring holder

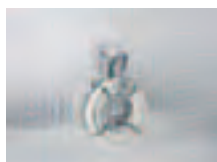

**SG-008**  
Cable holder with belt

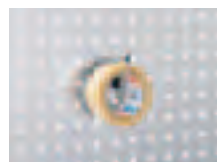

**SG-009**  
Slanting hook



**SG-010**  
Double hook



**SG-011**  
Flexible hook



**SG-012**  
U-Hook

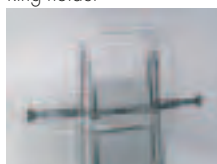

**SG-013**  
Belt and plastic hooks



**SG-014**  
Tool holder



**SG-015**  
Screwdriver holder



**SG-016**  
Can holder

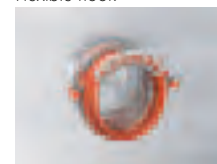

**SG-017**  
Cable holder

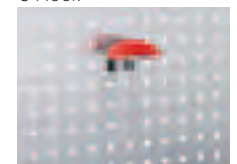

**SG-018**  
U-Hook



**SG-019**  
Rubber belt

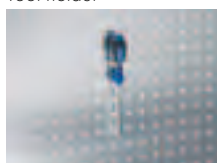

**SG-020**  
Tool clamp



**SG-021**  
Double tool clamp



**SG-022**  
Bottle holder

# UT-BOX SCREW MATERIAL PICKING

## UT-BOX SCREW MATERIAL PICKING



- Visual quantity control
- Various diameters and formats
- Protection from environmental pollution
- Simple insertion and removal of screw material
- Adjustable length
- Sliders for locking the supply
- Kanban rings for indicating level
- Simple installation on workbenches
- Structured supply
- Fixed or swivel structures
- Job satisfaction increasing
- Better productivity through higher precision
- ESD version available

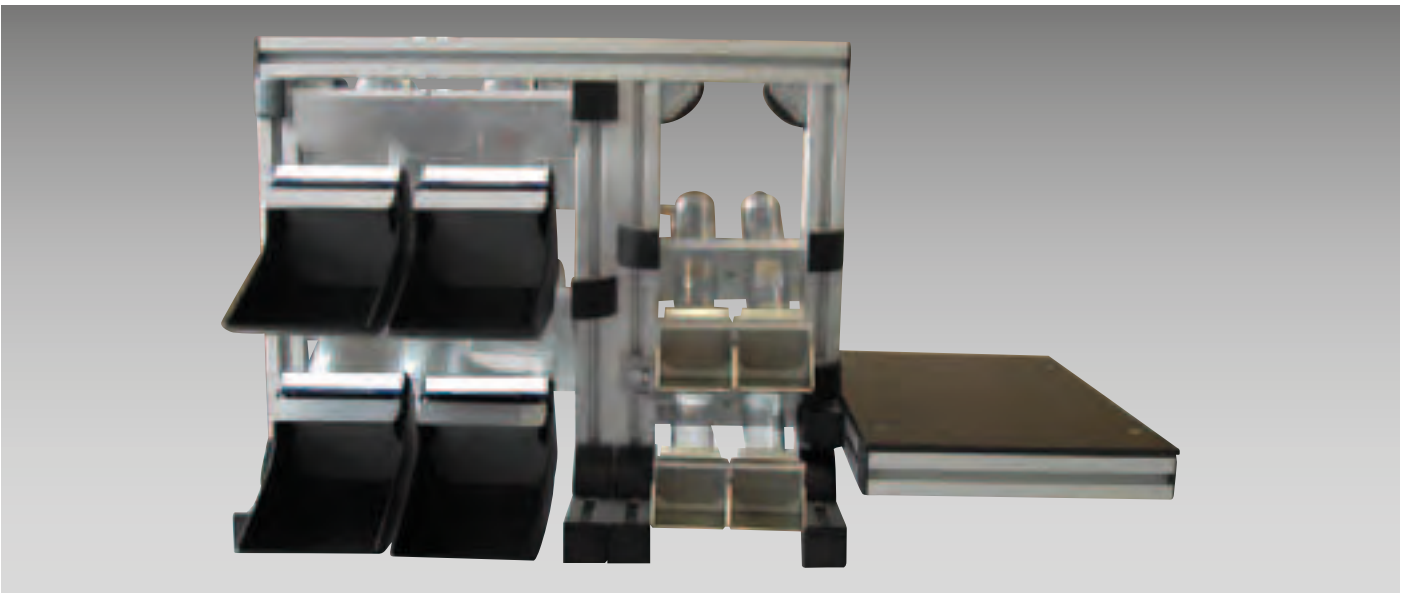
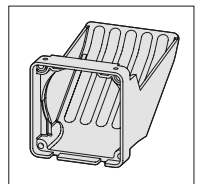
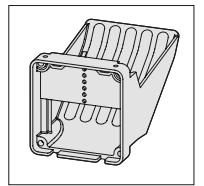
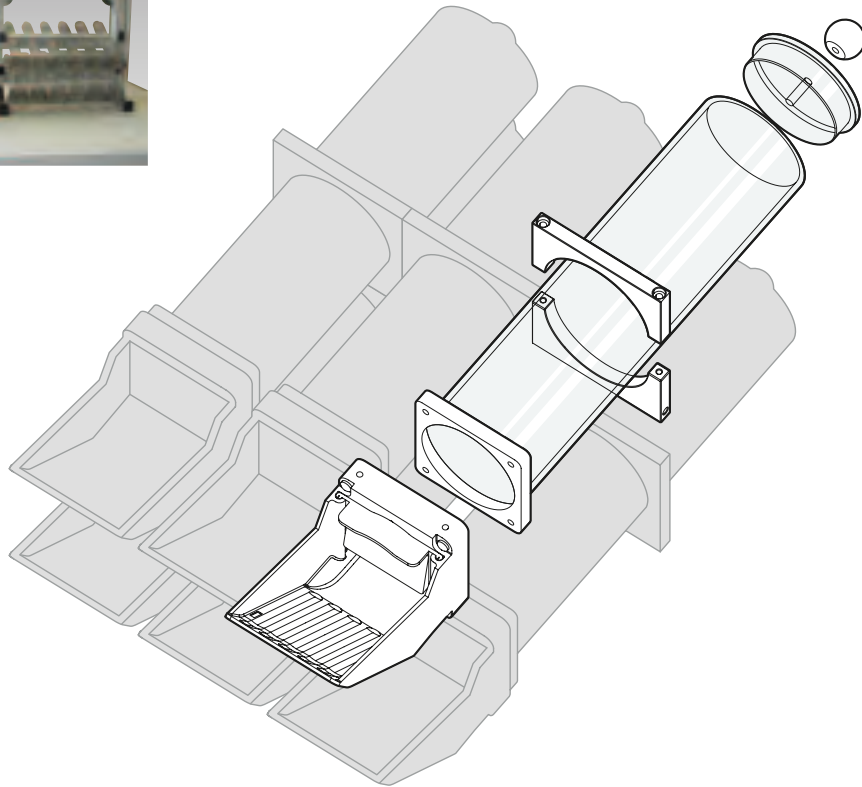
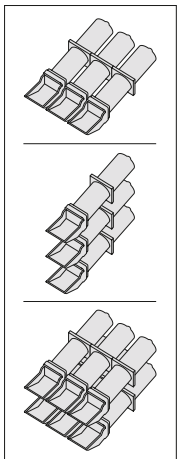
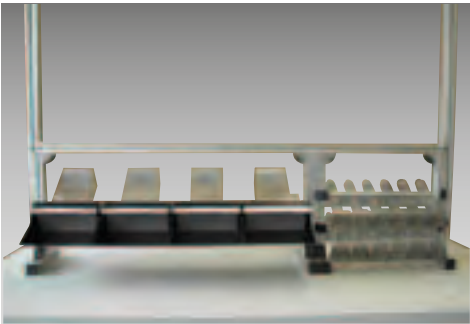

## VERSIONS

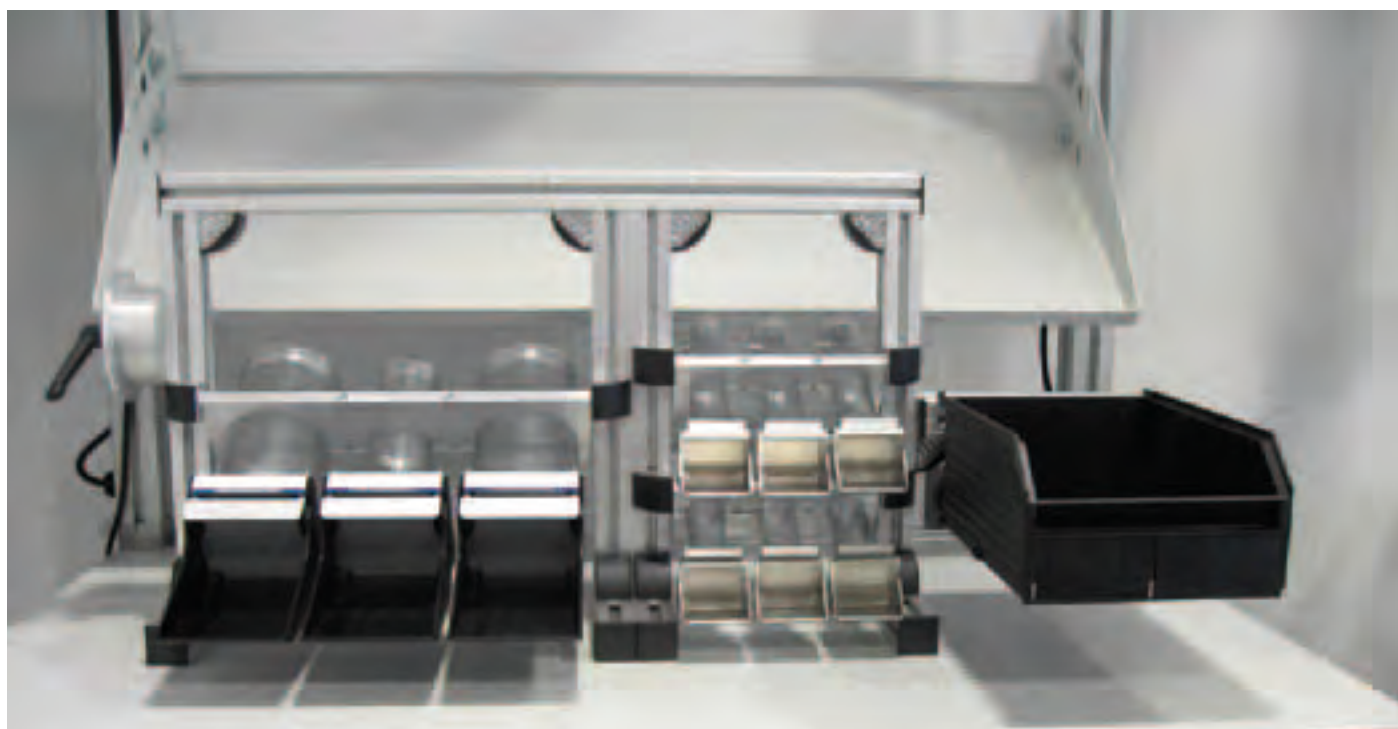

103

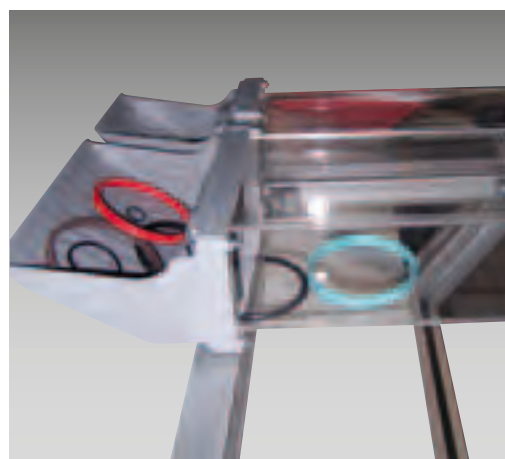
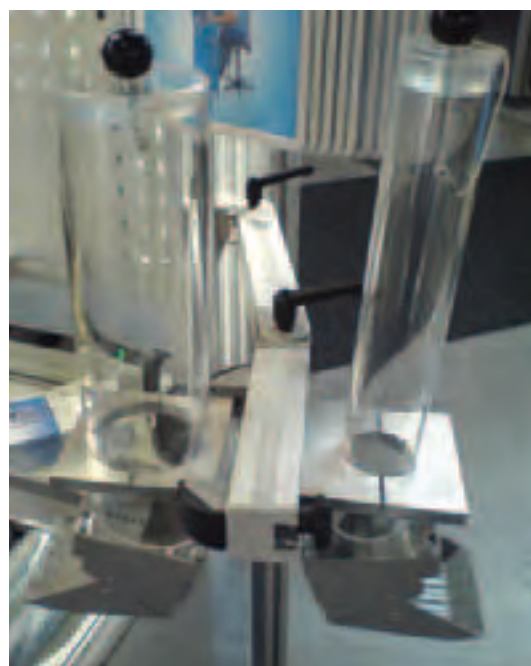

# ERGONOMIC MANIPULATORS FOR SCREWDRIVERS

## Telescopic Manipulator of carbon fiber

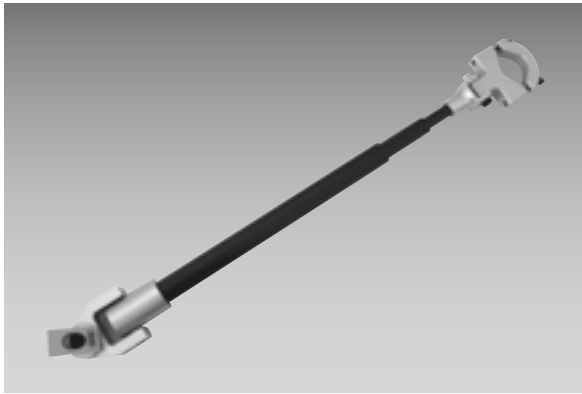

More ergonomics and less effort. Total movement freedom.  
Available for straight or pistol tools.

For other versions please contact our sales department.

## Aluminium sliding Manipulator



More ergonomics and less effort. Better repeatability.

For other versions please contact our sales department.

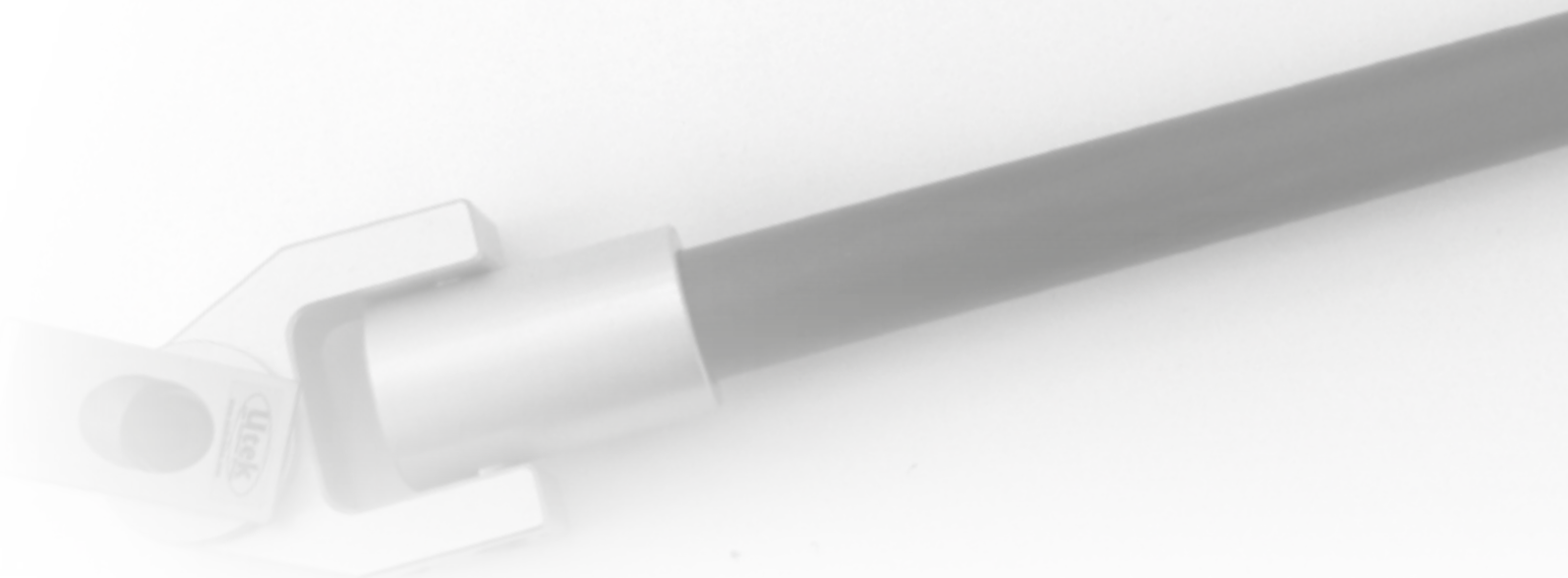

## VERSIONS



Code	<b>UT-BRT12</b>	<b>UT-BRT25</b>
Max. torque	12NM	25NM
Stroke	450-1000mm	450-950mm
Ø Fitting (mm)	28-40mm	30-50mm
Colours	01 02 04 05 09	
Price €		

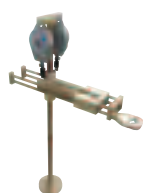

Code	<b>UT-BRS12</b>	<b>UT-BRS25</b>	<b>UT-BRS75</b>
Max. torque	12NM	25NM	75NM
Stroke	210mm	395mm	210mm
Dimensions	205-355mm	260-460mm	205-355mm
Max. loading capacity (kg)	5	10	10
Height	1000	1000	1000
Ø Pliers (mm)	28-50	28-50	On request
Price €			

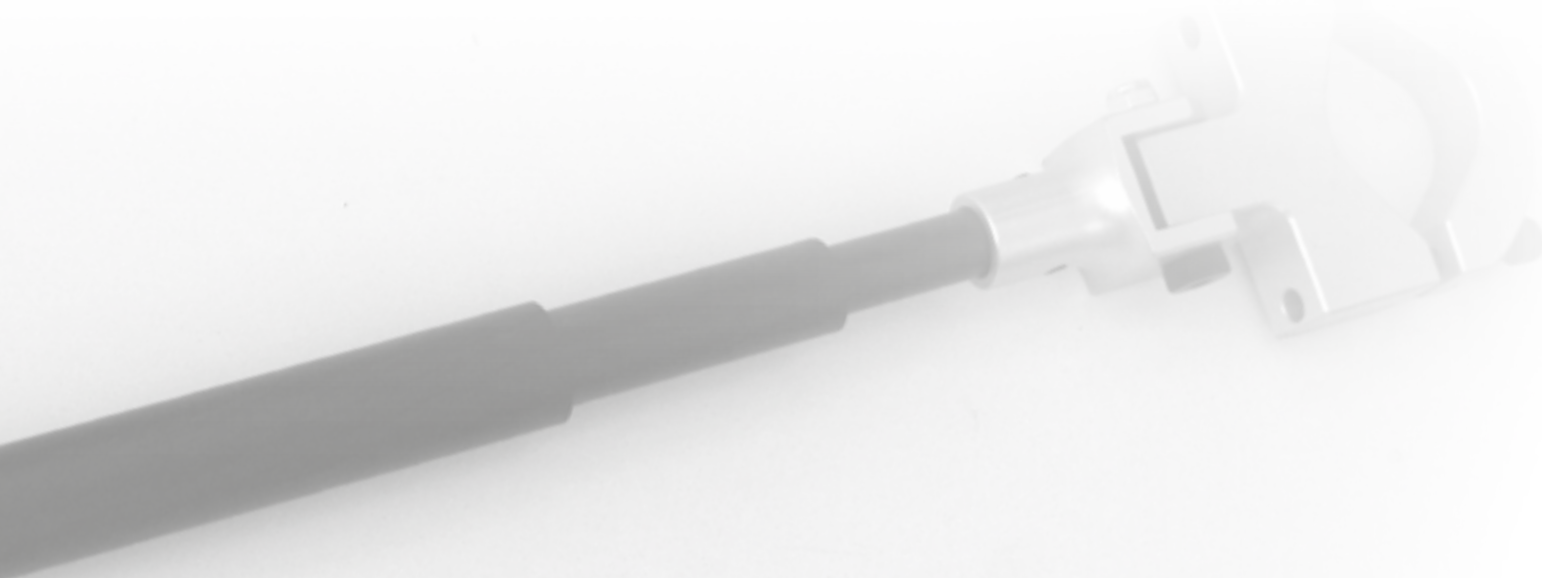



# TERMS AND CONDITIONS

## Supply and sale of goods is subject to the following standard terms and conditions.

### 1) Field of application

1.1 Following terms and conditions apply to all contracts for the sale of goods made between the customer and the seller company (UTEK Srl).

Unless expressly agreed in writing and signed by an authorised signatory of Utek, any variation to these terms and conditions shall be inapplicable.

These terms and conditions replace any other terms and conditions issued by the customer or any oral agreements between the parties.

1.2 We reserve the right to alter, add and subtract from these terms and conditions at any time. New terms and conditions will apply to all contracts made thirty (30) days after the date of notification.

### 2) Contract

2.1 Orders shall contain description, prices and delivery terms of the products ordered.

2.2 We are entitled to accept customer's offers (I) by sending (by e-mail, fax or telematic means) an order confirmation, or (II) by delivering the goods ordered without written order confirmation. (III) If the order confirmation differs from the customer's order, our order confirmation is considered to be accepted by the customer unless this latter submits written objections within two (2) working days after receipt of confirmation.

2.3 An order, once accepted, cannot be cancelled without our written consent.

### 3) Prices

3.1 The prices of the products are set by the price list in force on the day of order placement. If a product is not on price list or price list is not available, the prices are those indicated in the order or in the written order confirmation. Unless otherwise agreed in writing, prices are ex-works, exclusive of VAT and calculated net without any discounts. Prices do not include packaging, transport and shipping costs. These costs will be covered by the customer.

3.2 We reserve the right to change our prices at any time without notice and with immediate effect, due to conditions outside of our control (e.g.: changes in cost of raw materials, labour or in currency rate). In all other cases we will communicate to customers about the possible changes; in which case the new prices apply to all orders received thirty (30) days after the date of notification.

### 4) Delivery

4.1 Unless otherwise agreed in writing, the delivery shall be Ex Works in accordance with the latest version of the ICC Incoterms. If the customer requires the goods to be delivered, the delivery will be carried out at the customer's risk and expense.

4.2 Unless delivery terms are stated in the order or in the order confirmation, the delivery shall be carried out within sixty (60) days from the first working day after the order confirmation. According to art. 1457 of the Italian Civil Code, delivery terms are non-binding and do not include any transportation time.

4.3 Without prejudice to Art. 4.2, we are not liable for delivery delays or failures caused by factors outside of our control, e.g.:

- a. Delayed or improper delivery instruction;
- b. Difficulties in the supply of raw materials;
- c. Production or order planning problems;
- d. Partial or general strike, electricity blackouts, natural disasters, measures taken by public authorities, transport difficulties, terror attacks and other factors of force majeure;
- e. Carrier delays.

4.4 If one of these events occurs, the customer does not have the right to cancel the order, or to claim damages compensation or other kinds of compensation.

### 5) Transport

5.1 Unless otherwise agreed in writing, carriage will be always arranged at the customer's risk and expense. Unless otherwise indicated by the customer or unless the customer requires the goods to be delivered in accordance with Art. 4.1, we will choose the most appropriate delivery method.

### 6) Payment

6.1 Unless otherwise agreed in writing, invoice shall be issued on the day of order acceptance or on the day of delivery.

6.2 All payments are in Euro and within thirty (30) days from the last day of the month of the invoice.

6.3 If payment is not received within this time, we have the right to collect default interest at the rate determined by d.l. n. 231/02.

6.4 If payment is not received or delayed for more than thirty (30) days, we reserve the right to suspend the delivery or cancel all subscribed agreements. In which case the customer does not have the right to claim any compensation.

6.5 All claims on products or delivery do not justify payment failure or delay.

## **7) Non-conformity**

7.1 Any design or quantity deviations shall be notified within five (5) days after delivery. Otherwise the goods will be deemed to have been accepted.

## **8) Warranty**

8.1 Our manufacturer's warranty covers material and manufacturing defects.

8.2 The warranty does not covers defects due to: (I) Transport damage; (II) Improper use; (III) Non-observance of assembly instructions or any other technical instructions about the products; (IV) Any work or alteration to the goods carried out without our approval.

8.3 Provided that deviations are covered by this warranty and are notified within five (5) days after delivery, we will repair or replace defective products or defective parts at our discretion. The customer shall notify any apparent defects within eight (8) days after delivery; and any latent defects within eight (8) days after discovery. Unless otherwise agreed, the customer shall return defective products to us or any other indicated place at the customer's expense, to enable us to carry out the necessary inspections. The warranty does not cover defects or damages caused by improper assembly carried out by the customer or the consumer.

8.4 In case of payment failure, the customer has no right to make warranty claims. This concerns not only the payment of defective products, but also that of other products.

8.5 Without prejudice to Art. 8.3 and except in case of gross negligence or wilful misconduct, we decline any liability for any damage arising from or caused by the defects of the products. In any case we are not responsible for any direct or indirect damage, as downtime losses or profit ceasing.

8.6 In any case the indemnification amount will not exceed the total value of defective products.

## **9) Copyright**

9.1 This catalogue may not be reproduced in any form or by any means, in whole or in part. All rights reserved.

## **10) Adverse change in customer financial condition**

10.1 Should customer's financial condition become unsatisfactory, we have the right to suspend our obligations in accordance with Art. 1461 of the Italian Civil Code.

## **11) Minimum charge**

11.1 Minimum net order value is Euro 100.00.

## **12) Retention of title**

12.1 We will retain the legal ownership of the goods until full payment has been made. The customer shall perform all local requirements to ensure the enforceability of this clause against third parties, including entering in apposite registers, where locally required.

## **13) Law and jurisdiction**

13.1 You agree that the sole venue and jurisdiction for any and all disputes arising from or related to these Terms and Conditions shall be the Court in Reggio Emilia.



**UTEK srl**

Via Luciano Lama, 8 - Villa Argine  
42023 Cadelbosco di Sopra (RE) - Italy  
Tel. +39.0522.958945 - Fax +39.0522.912181  
info@utekvision.com - www.utekvision.com

Area distributor: